

THREE 71018 SHIMS ARE NORMAL
MORE OR LESS SHIM CAN BE USED
TO CENTER THE CALIPER

CALIPER MOUNTS IN THE
SAME APPROXIMATE
POSITION AS ORIGINAL
CALIPER

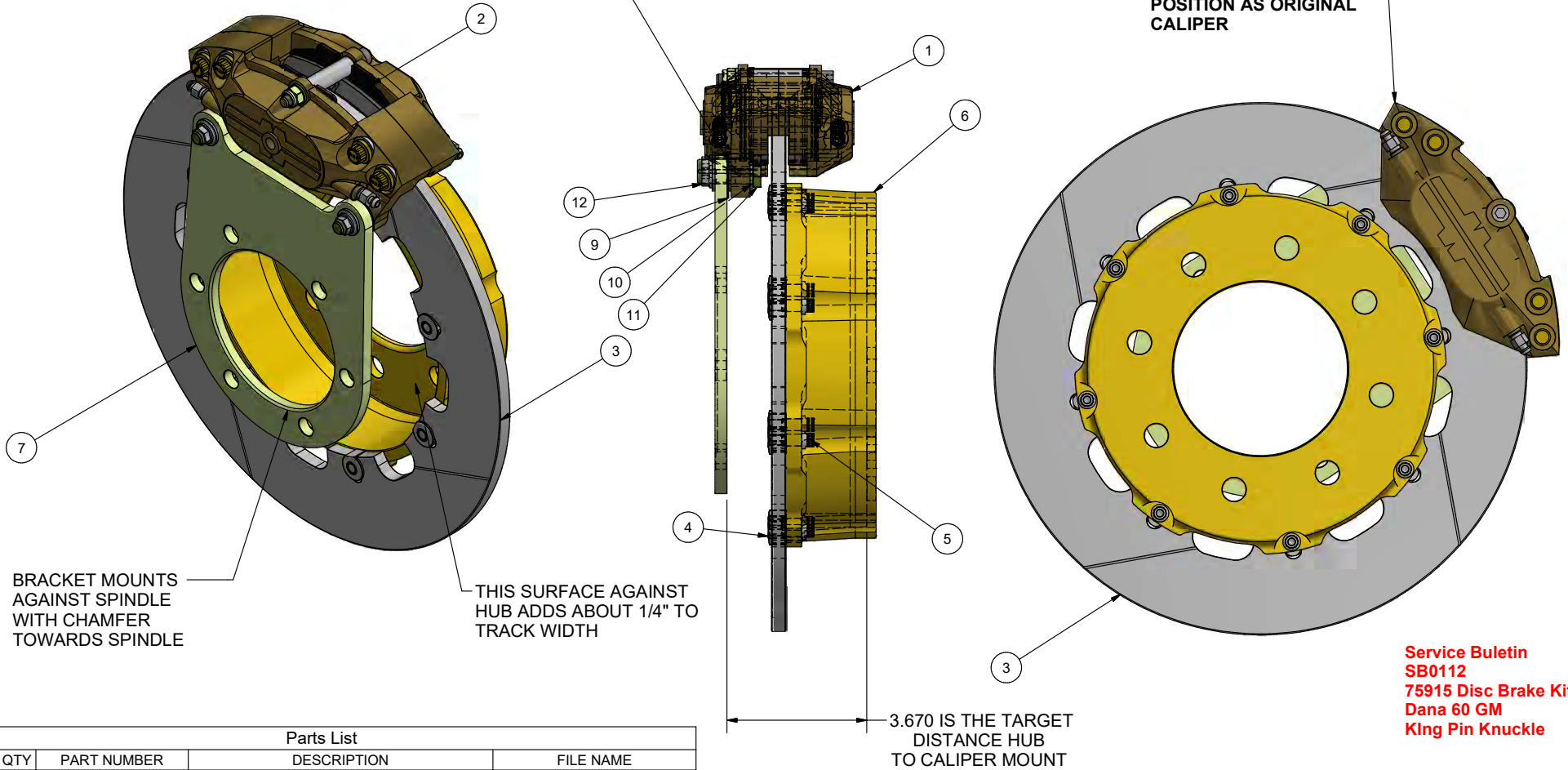

BRACKET MOUNTS
AGAINST SPINDLE
WITH CHAMFER
TOWARDS SPINDLE

THIS SURFACE AGAINST
HUB ADDS ABOUT 1/4" TO
TRACK WIDTH

3.670 IS THE TARGET
DISTANCE HUB
TO CALIPER MOUNT

QUANTITIES SHOWN ARE FOR
SINGLE SIDE
KIT HAS DOUBLE THOSE
AMOUNTS

**Service Bulletin
SB0112
75915 Disc Brake Kit
Dana 60 GM
King Pin Knuckle**

Parts List

ITEM	QTY	PART NUMBER	DESCRIPTION	FILE NAME
1	1	81100	CALIPER ASSEMBLY, 4 PISTON REV N OR LATER	AS0078.iam
2	2	81130-F350	FERODO HI-FRICTION LINING	AS004863IN.iam
3	1	71029	DISC, 14" 710XX & 759XX BRAKE KIT	004854IN.ipt
4	8	71032	BUTTON, DRIVE FOR .375" SLOTTED ROTORS	001853IN.ipt
5	8	71033	BOLT, 12 POINT BRAKE ADAPTOR	001855IN.ipt
6	1	75915-2	ADAPTOR, BRAKE GM DANA 60 FRONT	004941IN-2.ipt
7	1	75915-1 MOD	MOUNT, CALIPER GM DANA 60 FRONT	004941IN-1.ipt
9	6	71018	SHIM, CALIPER SPACER .015	000990IN.ipt
10	4	AN122584	WASHER, HARD 3/8 .078 THICK	AN122584.ipt
11	2	AN6-13A	BOLT, AIRFRAME 3/8 X 1.453	AN6-13A.ipt
12	2	NAS1296-6	NUT, JET TYPE 3/8-24	NAS1296-6.ipt

THIS IS A SOURCE CONTROLLED DRAWING. PART REPRODUCTION BY OTHERS NOT PERMITTED.

MATERIAL		HEAT TREAT	
		PROTECTIVE FINISH	
765 SOUTH PIERCE AVE, LOUISVILLE, CO 80027 <small>THIS DOCUMENT CONTAINS PROPRIETARY INFORMATION. IT MAY NOT BE REPRODUCED, TRANSMITTED TO OTHER DOCUMENTS, DISCLOSED TO OTHERS, USED FOR MANUFACTURING OR ANY OTHER PURPOSE WITHOUT PRIOR WRITTEN PERMISSION.</small>			
Z:\InventorFiles\Assembly_Files\AS004941IN.iam		DATE: 04/18/2020 03:23 PM	
STOCK INFORMATION		MACHINING TOLERANCES	
TITLE: BRAKE KIT FRONT 'GM DANA 60		PART NUMBER: 75915	
BAR LENGTH: WEIGHT: .XX .XXX .XXXX X		CHARGE: SHEET NO: 1	
YIELDS PER BAR: .015 .005 .0005 1/2			
GROSS WEIGHT (PART): SURFACE FINISH UNLESS NOTED V25			