

# CONTINGENCY VERIFICATION



765 S Pierce Ave  
303-665-6901

Louisville, CO 80027  
303-665-7021 (Fax)

Bulletin #91 page 1 of 2

## COMPLETE DIFFERENTIALS

April 16, 2015

### CONTINGENCY REQUIREMENTS:

VEHICLE MUST HAVE:

A) A COMPLETE MW REAR WITH BRAKES, AXLES, AND THIRDMEMBER. CAN BE MODULAR OR STEEL HOUSING. MW HI-TORQUE AXLE AND DISC BRAKE OR MARK WILLIAMS DRIVELINE COMPONENTS CONTINGENCY DECALS AFFIXED TO BOTH SIDES OF THE RACE CAR THROUGHOUT THE ENTIRE EVENT.

OR

B) A MW COMPLETE FULL FLOATER ASSEMBLY WITH A COMPLETE MW DISC BRAKE KIT WITH MW CALIPERS AND CONTINGENCY DECALS AFFIXED TO BOTH SIDES OF THE RACE CAR THROUGHOUT THE ENTIRE EVENT. A FULL FLOATER ASSEMBLY CONSISTS OF THE FOLLOWING PARTS: HUBS, SPINDLES, BRAKE CALIPERS, ROTORS, DOUBLE SPLINE AXLES, DRIVEPLATES, AND COVERS. THE USE OF MW FLOATER SHAFTS WITH OTHER MANUFACTURERS HUB ASSEMBLIES DOES NOT MEET OUR CONTINGENCY REQUIREMENTS.

### IDENTIFICATION of MW COMPONENTS:

Each MW modular rear will have one of three blue name plates below the filler cap. All name plates are a blue background with white lettering. All of the nameplates have a Mark Williams Enterprises logo, and "Louisville, CO"



Complete 11" Modular 4 link Floater Assembly

MW full floater assembly with cover plate. Cover plate has a blue anodized background and a silver foreground.

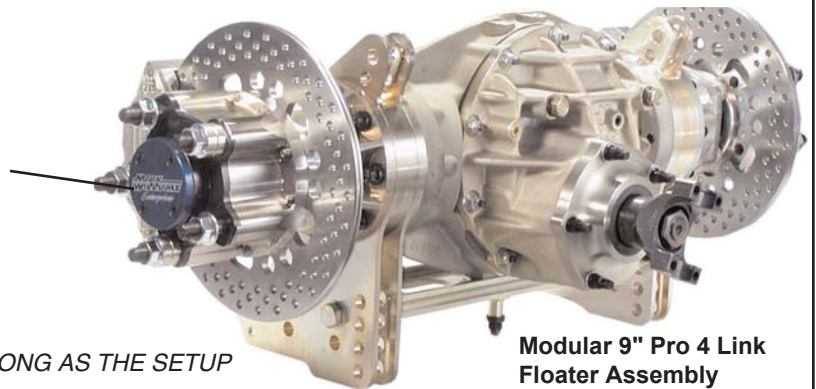

Modular 9" Pro 4 Link Floater Assembly

### NOTE ABOUT THIRD-PARTY HOUSINGS :

THIRD-PARTY AXLE HOUSING IS ACCEPTABLE AS LONG AS THE SETUP HAS MW THIRDMEMBER, BRAKES, & AXLES.



All MW thirdbmembers have MW cast just about the pinion support.



Modular 9" Econo/Comp Assembly

Flanged Axle assemblies show decal through wheel centers



# CONTINGENCY VERIFICATION



765 S Pierce Ave  
303-665-6901

Louisville, CO 80027  
303-665-7021 (Fax)

Bulletin #91 page 2 of 2

## COMPLETE DIFFERENTIALS

April 16, 2015

### VISUAL VERIFICATION OF BRAKES :

- 1) DISC BRAKE KIT MUST HAVE MW ALUMINUM CALIPERS WITH MW LOGO CAST ON BOTH SIDES OF BOTH CALIPERS.
- 2) MW DECAL MUST BE DISPLAYED ON BOTH SIDES CAR.

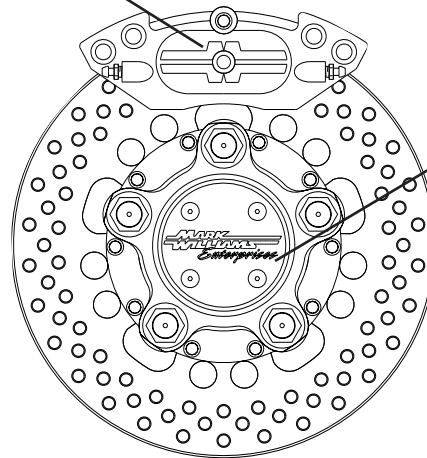
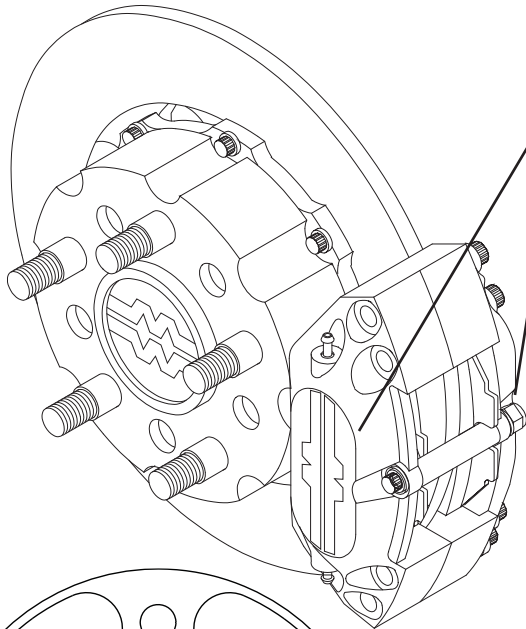

MW full floater assembly with cover plate. Cover plate has a blue anodized background and a silver foreground.

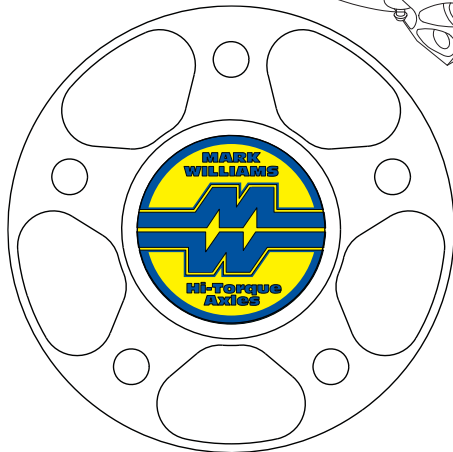

### VISUAL VERIFICATION OF FLOATER ASSEMBLIES:

FULL FLOATER ASSEMBLIES MUST HAVE MW ENGRAVED BLUE ANODIZED DRIVE PLATE COVERS ATTACHED. THE DRIVE PLATE COVERS MUST BE CLEARLY VISIBLE THROUGH THE WHEEL CENTERS. AS A RESULT, WHEEL CENTER CAPS MAY NOT BE USED. IN ADDITION TO THE DRIVE PLATE COVERS, VERIFICATION INCLUDES THE PRESENCE OF MW LOGOS CAST INTO THE BRAKE CALIPERS.

### VISUAL VERIFICATION OF FLANGE TYPE AXLES:

FLANGE TYPE AXLES MUST HAVE MW NAME PLATES ATTACHED. THE AXLE NAME PLATES MUST BE CLEARLY VISIBLE THROUGH THE WHEEL CENTERS. AS A RESULT, WHEEL CENTER CAPS MAY NOT BE USED.

Name plate has a yellow background and a blue foreground.

### DECAL DISPLAY :

1) MARK WILLIAMS AXLE **AND** DISC BRAKE DECALS **OR** MW DRIVELINE COMPONENTS DECALS MUST BE DISPLAYED ON BOTH SIDES OF THE RACE CAR THROUGHOUT THE ENTIRE RACING EVENT. DECALS ARE AVAILABLE BY REQUESTING DECALS FROM MARK WILLIAMS ENTERPRISES, INC 1-800-525-1963. PAINTED REPRODUCTIONS OF MW DECALS ARE NOT ACCEPTABLE.



Mark Williams Driveline Components decal has no background. Mark Williams is written in a blue stylized font. Driveline Components is written in a gray font with a black outline.

OR



MW Hi-Torque axle flange with name plate. Name plate has a yellow background and a blue foreground.

AND



Mark Williams Disc Brake decal has no background. Mark Williams is written in a blue stylized font. Disc Brakes is in yellow font with a blue outline.