

CONTINGENCY VERIFICATION

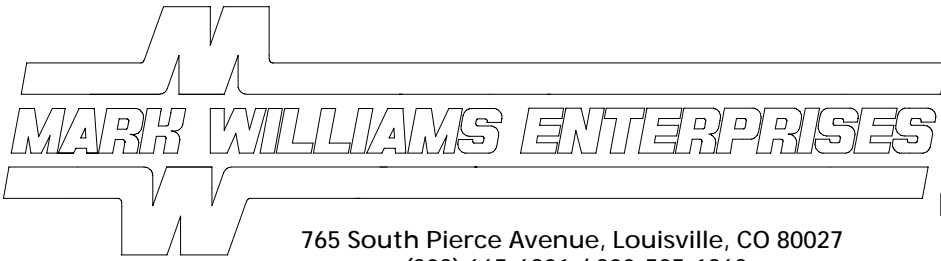

765 South Pierce Avenue, Louisville, CO 80027
(303) 665-6901 / 800-525-1963

SERVICE BULLETIN

NO. 0033 PAGE 1 OF 1

DRIVESHAFT CONTINGENCY

December 31, 1996

CONTINGENCY REQUIREMENTS :

MUST HAVE A 4130 CHROMOLY OR ALUMINUM DRIVESHAFT AND A M-W SLIP YOKE. (39600 MILD STEEL DRIVESHAFTS ARE NOT ELIGIBLE.)

PART NUMBER :	DESCRIPTIONS :
39800	M-W 4130 CHROMOLY DRIVESHAFT
39900	M-W ALUMINUM DRIVESHAFT

To be eligible for contingency a Mark Williams Enterprises, Inc. manufactured slip yoke must be used in conjunction with 39800 4130 chromoly driveshaft or 39900 aluminum driveshaft .

VISUAL VERIFICATION :

- 1) M-W NAME TAG WITH SERIAL NUMBER, THE SERIAL NUMBER WILL ALSO BE STAMPED ON SHAFT NEXT TO TAG.
- 2) SHAFT MUST HAVE M-W SLIP YOKE WITH M-W LOGO AND PART NUMBER ENGRAVED ON YOKE.
- 3) SHAFT IS NOT USED WITH SOLID REAR SUSPENSION (DRAGSTER AND FUNNY CARS)

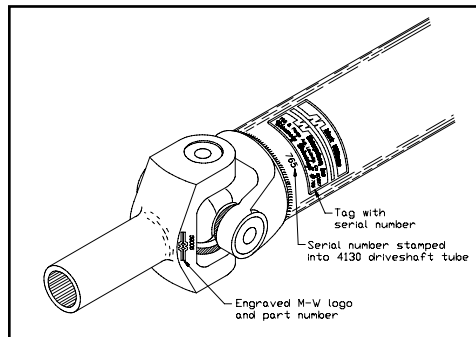

DECAL DISPLAY :

1) 3-1/4" X 11-1/2" MARK WILLIAMS DRIVESHAFT DECAL MUST BE DISPLAYED ON BOTH SIDES OF RACE CAR THROUGHOUT THE ENTIRE EVENT. PAINTED FACSIMILE OF DECAL IS NOT ACCEPTABLE.

2) DECAL'S ARE AVAILABLE UPON REQUEST AT M-W DISPLAY UNIT ON THE MIDWAY AT ALL NHRA NATIONAL EVENTS OR BY CALLING 1-800-525-1963 OR (303) 665-6901.