

Axle Length Calculator:

Axle Length = Measurement 1.) above + 3.359"

Axle Length = Measurement 2.) above + 4.923"

Helpful Measurements:

Wheel clearance diameter = 16"

Top of caliper to bottom of rotor = 14.9"

Customer Name _____

Customer # _____

Customer PO# _____

Order # _____

S/O # _____

SERVICE BULLETIN 0100

Call for housing
length measurements

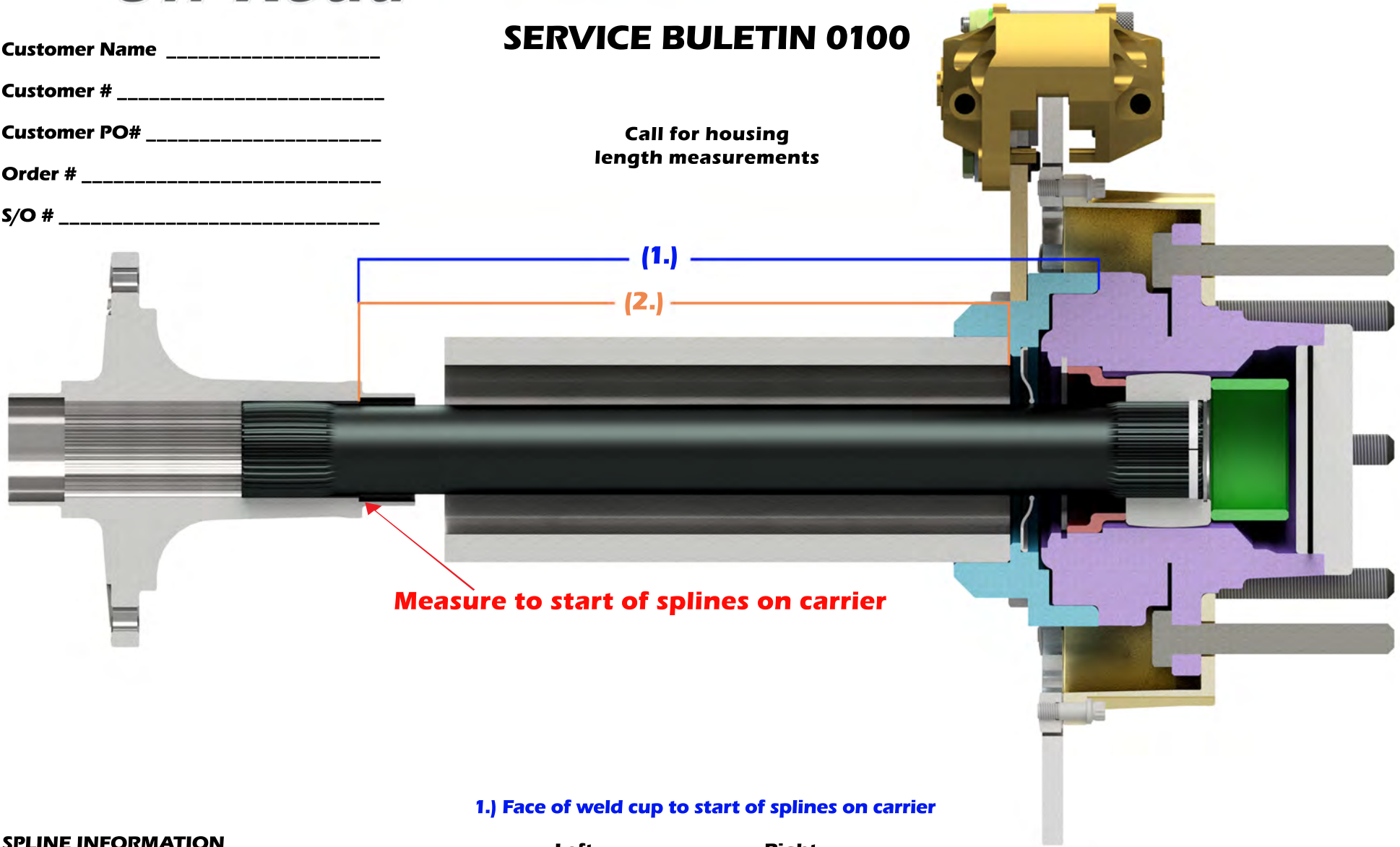

Measure to start of splines on carrier

1.) Face of weld cup to start of splines on carrier

Left _____ Right _____

2.) End of tube to start of splines on carrier

Left _____ Right _____

SPLINE INFORMATION

Tooth Count: _____

Spool or OEM Center Carrier: _____

AXLE MATERIAL / PART NUMBER

4340 - P/N 50255

300M - P/N 50265