

SPACER FOR OEM STUD (8) INSTALL BEFORE PRESSING STUD IN HUB

THIS SIDE IS AGAINST KNUCKLE

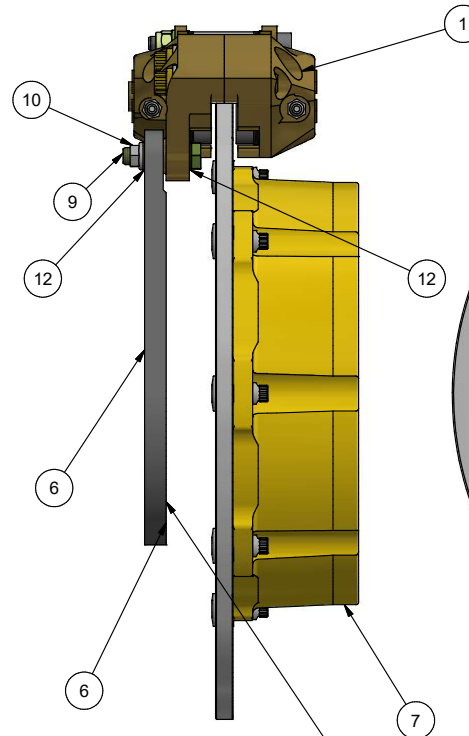

WHEEL HUB AGAINST THIS SURFACE. ADDS ABOUT 1/4" TO TRACK WIDTH.

SPINDLE AGAINST THIS SURFACE

CALIPER MOUNTS IN THE SAME APPROXIMATE POSITION AS ORIGINAL CALIPER

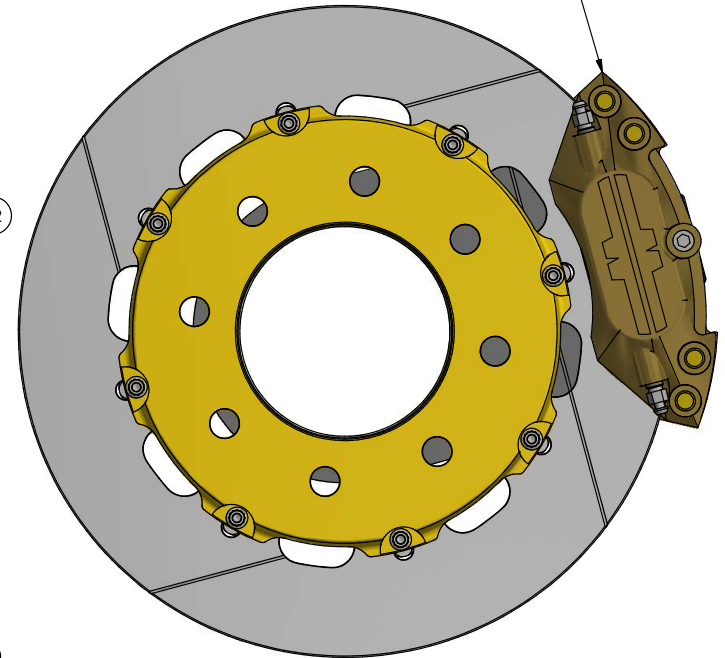

**Service Buletin  
SB0108  
75910 Disc Brake Kit  
Dana 60-'78 Ford  
King Pin Knuckle**

Parts List

ITEM	QTY	PART NUMBER	DESCRIPTION	FILE NAME
1	1	81100	CALIPER ASSEMBLY, 4 PISTON REV N OR LATER	AS0078.iam
2	2	81130-F350	FERODO HI-FRICTION LINING	AS004863IN.iam
3	1	71029	DISC, 14" 710XX & 759XX BRAKE KIT	004854IN.ipt
4	8	71032	BUTTON, DRIVE FOR .375" SLOTTED ROTORS	001853IN.ipt
5	8	71033	BOLT, 12 POINT BRAKE ADAPTOR	001855IN.ipt
6	1	75910-1	BRACKET, CALIPER MOUNT FORD DANA 60 FRONT	004939IN-1.ipt
7	1	75910-2	ADAPTOR, BRAKE HAT, FORD DANA 60 FRONT	004939IN-2.ipt
9	2	AN6-13A	BOLT, AIRFRAME 3/8 X 1.453	AN6-13A.ipt
10	2	NAS1296-6	NUT, JET TYPE 3/8-24	NAS1296-6.ipt
11	8	75910-3	WASHER, STUD SPACER 75910 BRAKE KIT	004939IN-3.ipt
12	4	AN960-616L	WASHER, 3/8" AIRCRAFT THIN	AN960-616L.ipt

QUANTITIES SHOWN ARE FOR SINGLE SIDE KIT HAS DOUBLE THOSE AMOUNTS

THIS IS A SOURCE CONTROLLED DRAWING. PART REPRODUCTION BY OTHERS NOT PERMITTED.

MATERIAL	HEAT TREAT	 <b>765 SOUTH PIERCE AVE, LOUISVILLE, CO 80027</b> <small>THIS DOCUMENT CONTAINS PROPRIETARY INFORMATION. IT MAY NOT BE REPRODUCED, TRANSFERRED TO OTHER DOCUMENTS, DISCLOSED TO OTHERS, USED FOR MANUFACTURING OR ANY OTHER PURPOSE WITHOUT PRIOR WRITTEN PERMISSION.</small> <small>© 1997 Mark Williams Enterprises</small>	
			<b>AS004939IN.iam</b> <small>11/12/06-19</small>
<small>Z:\InventorFiles\Assembly_Files\AS004939IN.iam</small>			
<b>STOCK INFORMATION</b>			<b>MACHINING TOLERANCES</b> <small>BAR LENGTH: WEIGHT: .XX .XXX .XXXX X</small> <small>YIELDS PER BAR: .015 .005 .0005 1/2</small> <small>GROSS WEIGHT (PART): SURFACE FINISH UNLESS NOTED V.75</small>
<small>SAVED DATE: 02/04/2020 03:58 PM</small>		<small>PART NUMBER: 75910 ASSY</small>	